

W1421 GENESYS Synthesis for ADS W1422 RF Architect for ADS

Data Sheet RF Architecture tools for ADS users

Overview

The Agilent GENESYS software (previously sold by Eagleware-Elanix) includes several unique tools for RF Architecture design that were not available to users of the Agilent Advanced Design System. ADS 2006A makes it possible to invoke these RF architecture tools from the ADS menus, and then transfer the resulting schematics back to ADS. Once the designs are in the ADS environment, the system implementation can continue, and then verified for system performance using the full capabilities of the Advanced Design System.

GENESYS products of particular interest to ADS users:

- SPECTRASYS
- WhatIF
- Synthesis (a collection of several circuit synthesis modules)

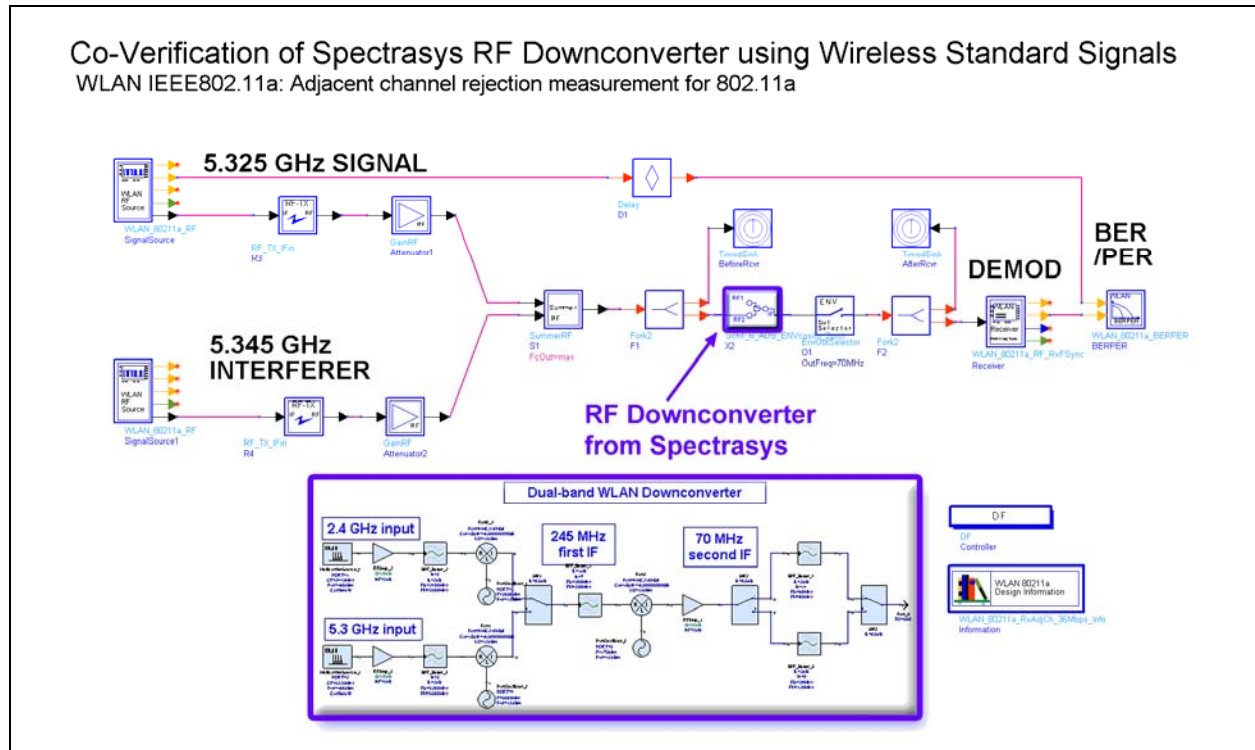

The figure shows a SPECTRASYS block diagram embedded as an analog subcircuit in a WLAN verification using the Ptolemy system simulator in ADS. The testbench is configured to characterize adjacent channel interference with real 802.11 sources, and is capable of including Momentum co-simulation, dynamic nonlinear amplifiers using Circuit Envelope, and real surface-mount part models. Only ADS allows this integration of dynamic, physical RF

effects with a working PHY at the system level, complete with baseband DSP, HDL/Matlab co-simulation of your algorithmic IP, and even waveforms from test equipment.

If you already use ADS Design Guides or the E8854 RF System Models within ADS, GENESYS Synthesis, SPECTRASYS, and WhatIF add unique capabilities for exploring RF architectures. SPECTRASYS includes an intuitive RF Budget analysis and SPARCA (spectral propagation and root-cause analysis) analysis. The spectral domain analysis retains the individual contributions and propagation paths for every harmonic and intermodulation product in the system, allowing you to identify not only troublesome spurious products, but also where they originated, and what to do about them. There is no comparable tool in ADS.

Further, SPECTRASYS need not be an island in your suite of RF tools, like other system tools and spreadsheets. The same design information can continue living into the overall system verification tools, bringing together a unique and connected RF System design flow. Together, these tools create a head-start toward a working design, and put designers “closer to the finish line.”

More detailed regarding the capabilities of the individual GENESYS modules is available at <http://www.eagleware.com>

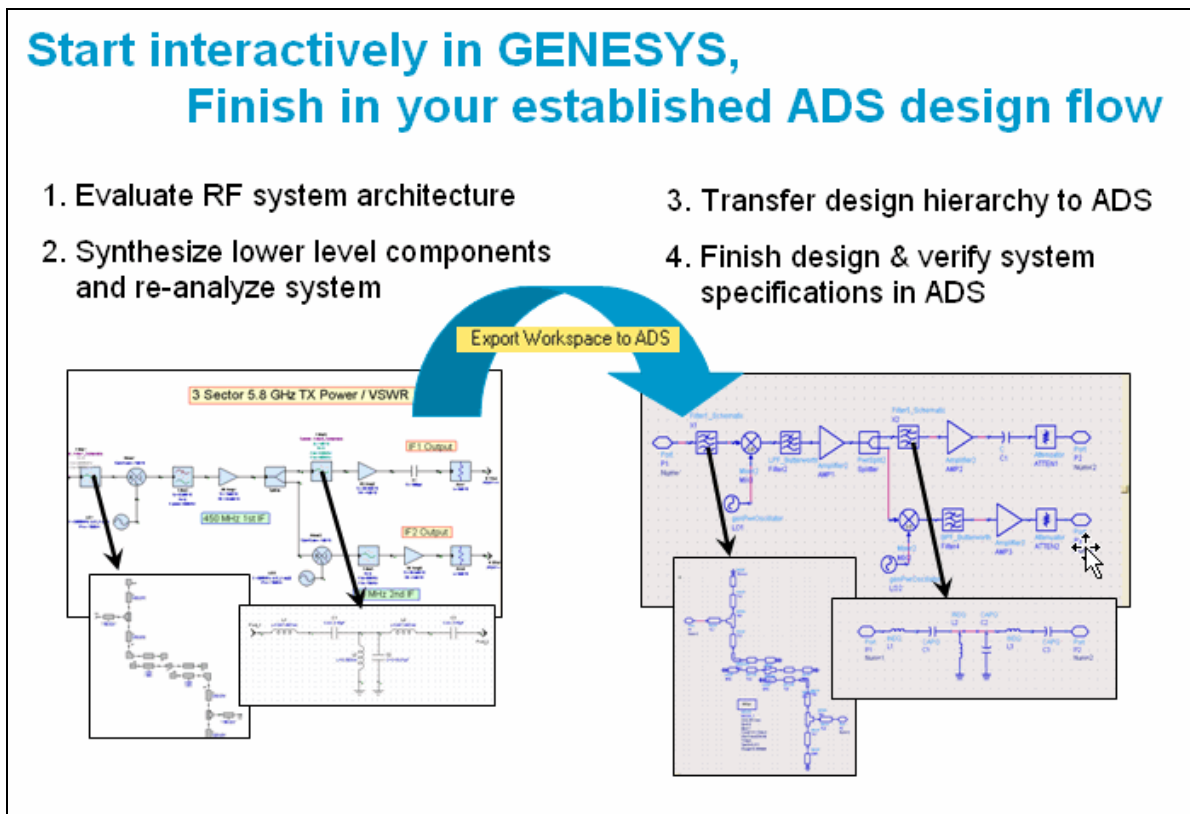

For ADS Users Without Access to GENESYS

If you do not currently own SPECTRASYS, WhatIF, or Synthesis, there are two new packages that make it easy to add them to your existing installation and licenses for ADS:

- W1421 GENESYS Synthesis for ADS (ADS codeword: *ads_circuit_synthesis*)
- W1422 RF Architect for ADS (ADS codeword: *ads_rf_architect*)

The W1421 and W1422 are licensed using ADS licensing mechanisms, even though they enable GENESYS features. Therefore, codewords for the W1421 and W1422 are requested using the normal ADS codeword processes, and appended to existing ADS license files. ADS users will need to install both the ADS and GENESYS software. An appropriate version of GENESYS is downloadable from the Software Download area of the Agilent EEs of Knowledge Center.

<http://www.agilent.com/find/eesof-knowledgecenter>

Because GENESYS and ADS need to run simultaneously for real-time transfers, special license-sharing capabilities have been programmed into the W1421 and W1422 modules to allow them to re-use basic ADS capabilities, such as Schematic, Data Display, frequency-domain Linear Simulation, and Layout.

To enjoy full use of SPECTRASYS schematics in ADS, it is helpful to have the appropriate libraries and simulators in ADS that analyze RF block-level components.

Required ADS modules	Helpful ADS modules
E8900 Schematic* E8901 Data Display* E8881 Linear simulator*	E8902 Layout* (<i>optional</i>) E8823 Momentum E8854 RF System Models, and either E8882 Harmonic Balance simulator E8883 Circuit Envelope Simulator or E8853 RF System Simulator E8826 Ptolemy simulator
* ADS license shared by GENESYS	

Easy to Add To An Established ADS Design Flow

What has been done to make it easy to add these tools to an established ADS Design Flow?

1. Coordinated Licensing

- ADS-style codewords served by PC or Unix-based license servers makes it easy to administer licenses for these GENESYS features.
- They simply add as Increment lines to your ADS license file, either nodelocked or network licensed.
- *No new license servers or daemons are required.*

2. Expanded File-based IFF import/export

- GENESYS has been enhanced to export a wider variety of system and circuit components to the ADS IFF file format. Likewise, ADS IFF has been enhanced to recognize a wider array of components from GENESYS.
- *Because Agilent owns and supports both platforms, we can improve both platforms simultaneously to facilitate this capability.*
- Note that there is not a 1:1 correspondence (mapping) of all possible components between the systems. Components that are common to both systems, such as R, L, C components, microstrip lines, and behavioral amplifiers, are mapped appropriately from GENESYS to ADS

3. Live communication

- Users can invoke the GENESYS software directly from the ADS menus
- The GENESYS schematics which result can be transferred back to a live ADS session
- *The design information moves directly into the ADS design flow, so that the system administrators of RF design tools do not need to support an additional platform or design database.*

For Existing GENESYS Users Who Also Use ADS

If you already have access to SPECTRASYS, WhatIF, or Synthesis, you do not need to purchase the W1421 or W1422.

You can link your existing GENESYS software to ADS 2006A by updating your GENESYS software to the 2006.10 version or later, and running ADS 2006A on the same PC. No additional set-up is required. With ADS 2006A, live schematic transfers are enabled from GENESYS to ADS while the two systems are running on the same PC. GENESYS users of Harbec, Cayenne, and other modules may also take advantage of other capabilities of the GENESYS environment. These capabilities are beyond the W1421 and W1422.

File-based transfers are possible where a direct, live connection is not practical, such as between GENESYS on a Windows PC, and ADS running on a Unix host.

How Are the W1421 and W1422 Different from Standalone Seats of GENESYS?

The W1421 and W1422 differ from the comparable standalone seats of GENESYS (W1411 and W1412) in these important ways:

1. The W1421 and W1422 allow Unix-based license servers for simple, central administration.
2. The W1421 and W1422 do not include a license for the GENESYS environment, only the RF tools. They also do not include additional GENESYS capabilities, such as Harbec, Cayenne, and other modules.
3. The W1421 and W1422 licenses allow GENESYS to re-use the ADS Schematic, Data Display, Linear, and Layout licenses of the ADS session running on that machine, thus minimizing the duplication of environments. This also creates a small cost advantage for the W1421 and W1422, relative to full, standalone seats of GENESYS.

Ordering Information

There are two new packages that can be added to your existing ADS configuration:

<p>W1421</p>	<p>GENESYS Synthesis for ADS includes ADS codeword “ads_circuit_synthesis”, which enables:</p> <ul style="list-style-type: none"> • 8 GENESYS Synthesis Modules <ul style="list-style-type: none"> – S/FILTER (M/FILTER + FILTER) – A/FILTER – EQUALIZE – MATCH – Advanced Transmission Line – SIGNAL CONTROL – OSCILLATOR – MIXER • Ability for GENESYS to run concurrently using existing ADS licenses* <ul style="list-style-type: none"> – Re-use existing E8900 ADS schematic (required) – Re-use existing E8901 ADS data display (required) – Re-use existing E8881 ADS linear simulation (required) – Re-use existing E8902 ADS layout (optional) <p><i>*ADS licenses not included with package; assumes prior ADS ownership</i></p>
<p>W1422</p>	<p>RF Architect for ADS includes ADS codeword “ads_rf_architect”, which enables:</p> <ul style="list-style-type: none"> • WhatIF frequency planner • SPECTRASYS system • 8 GENESYS Synthesis Modules (see above list) • Ability for GENESYS to run concurrently using existing ADS licenses* <ul style="list-style-type: none"> – Re-use existing E8900 ADS schematic (required) – Re-use existing E8901 ADS data display (required) – Re-use existing E8881 ADS linear simulation (required) – Re-use existing E8902 ADS layout (optional) <p><i>*ADS licenses not included with package; assumes prior ADS ownership</i></p>

Compare the W1421 and W1422 to these full Standalone GENESYS packages:

<p>W1411</p>	<p>W1411 Designer Plus includes as one package:</p> <ul style="list-style-type: none"> • All GENESYS Synthesis Modules (including PLL, T/LINE) • Package includes full standalone licenses for GENESYS “core” features <ul style="list-style-type: none"> – GENESYS schematic – GENESYS data display – GENESYS linear simulation – GENESYS layout
<p>W1412</p>	<p>RF Architect Plus includes as one package:</p> <ul style="list-style-type: none"> • WhatIF frequency planner • SPECTRASYS system • All GENESYS Synthesis Modules (including PLL, T/LINE) • Package includes full standalone licenses for GENESYS “core” features <ul style="list-style-type: none"> – GENESYS schematic – GENESYS data display – GENESYS linear simulation – GENESYS layout